

United States Patent

Cutler

[15] 3,657,460

[45] Apr. 18, 1972

[54] **ORGAN KEYBOARD SWITCHING SYSTEM**

[72] Inventor: Stanley Cutler, Van Nuys, Calif.

[73] Assignee: Mattel, Inc., Hawthorne, Calif.

[22] Filed: Jan. 22, 1971

[21] Appl. No.: 108,841

[52] U.S. Cl.84/1.01, 84/1.07, 84/DIG. 7, 200/166 J

[51] Int. Cl.G10h 1/00

[58] Field of Search84/1.01, 1.07, 1.08, 1.27, 84/423, 433, DIG. 7, 1.25; 338/154, 69; 200/166 T

[56] **References Cited**

UNITED STATES PATENTS

2,959,693	11/1960	Meyer.....	84/1.01 X
2,575,230	11/1951	Mork.....	84/1.01 X
2,848,920	8/1958	Lester.....	84/1.27
3,474,182	10/1969	Destelle.....	84/1.25
3,524,375	8/1970	Hopping.....	84/1.27 X
3,564,105	2/1971	Amano.....	84/1.01

3,041,568 6/1962 Bissonette et al.....84/DIG. 7
3,060,784 10/1962 Holt.....84/423

Primary Examiner—Lewis H. Myers

Assistant Examiner—U. Weldon

Attorney—Seymour A. Scholnick

[57] **ABSTRACT**

A switch assembly operated by the keys of an electronic organ to connect different tone generators to the loudspeaker, which is simple and which minimizes mechanical and electrical noises during closing of the switches. The assembly includes a row of resilient switch members connected to the loudspeaker and positioned to be individually deflected up against a contact assembly. The contact assembly includes a circuit board with numerous conductive pads arranged in a row above the row of switch members, a pair of insulating spacer strips extending along either side of the row of pads, and an intermediate strip of conductive plastic fastened to the spacer strips. When a key is depressed, a corresponding switch member is deflected upwardly to press a region of the plastic strip against a conductive pad.

8 Claims, 5 Drawing Figures

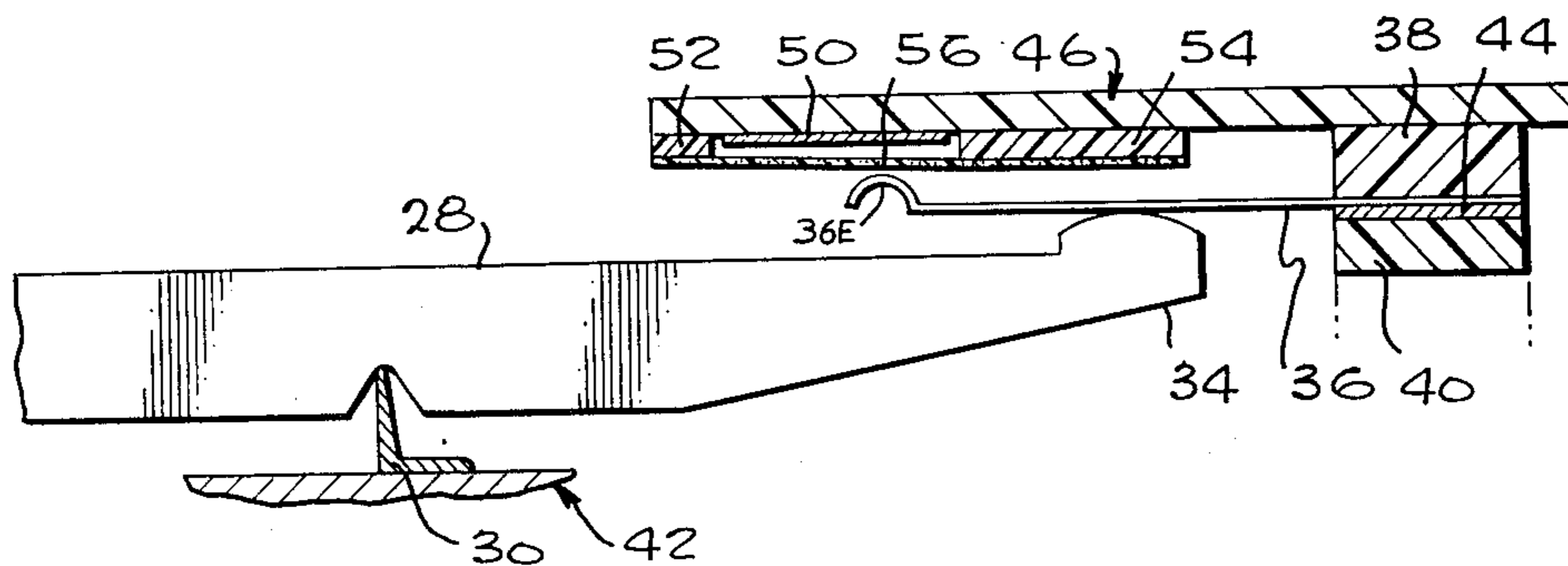

Patented April 18, 1972

3,657,460

2 Sheets-Sheet 1

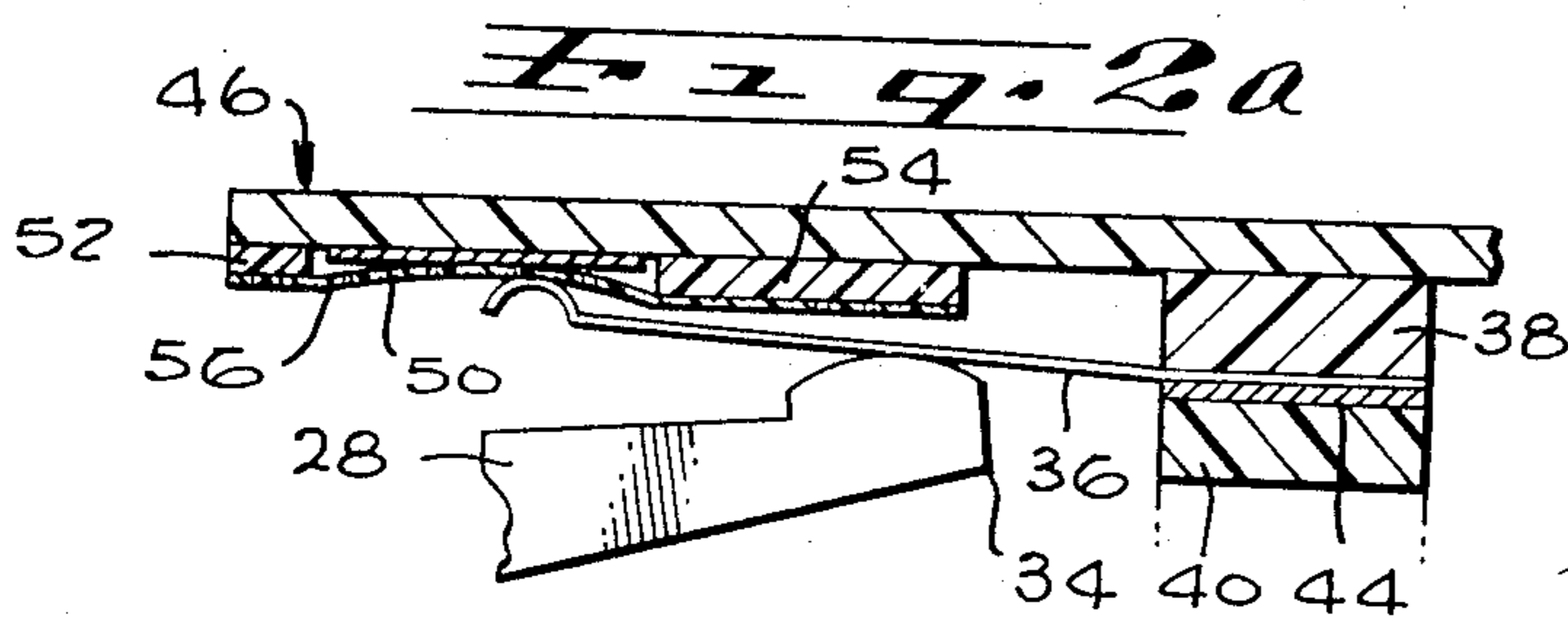
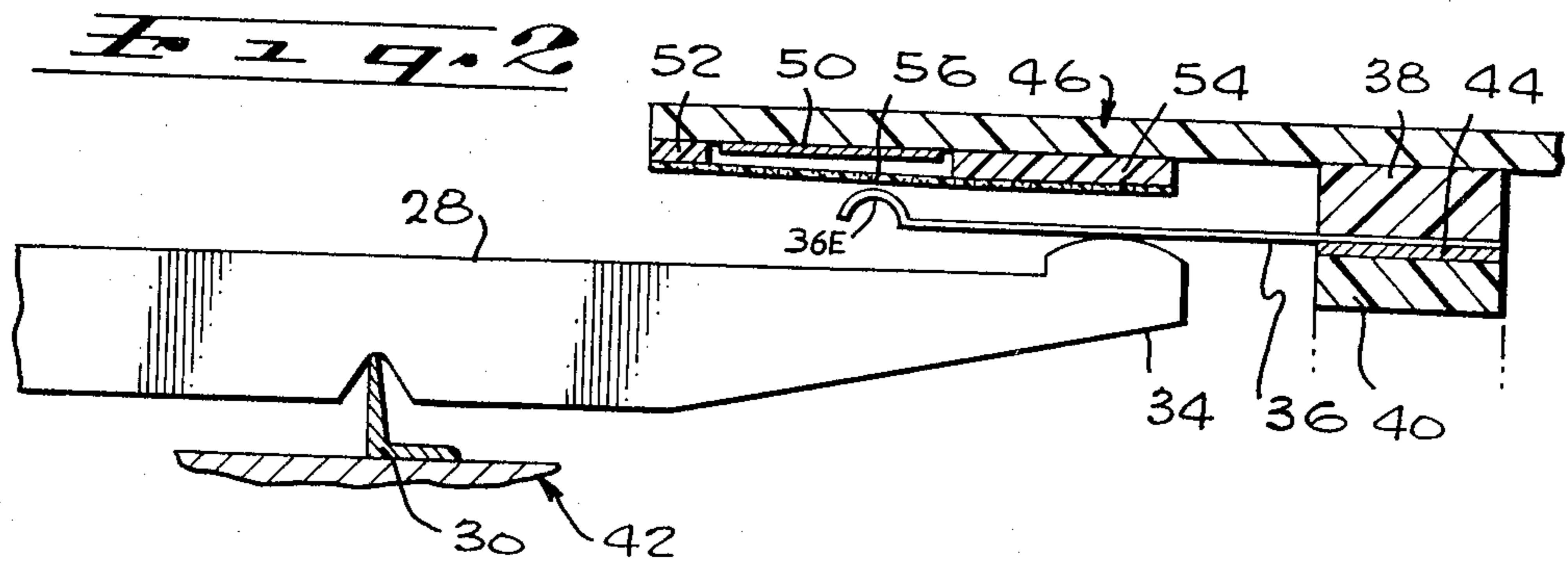
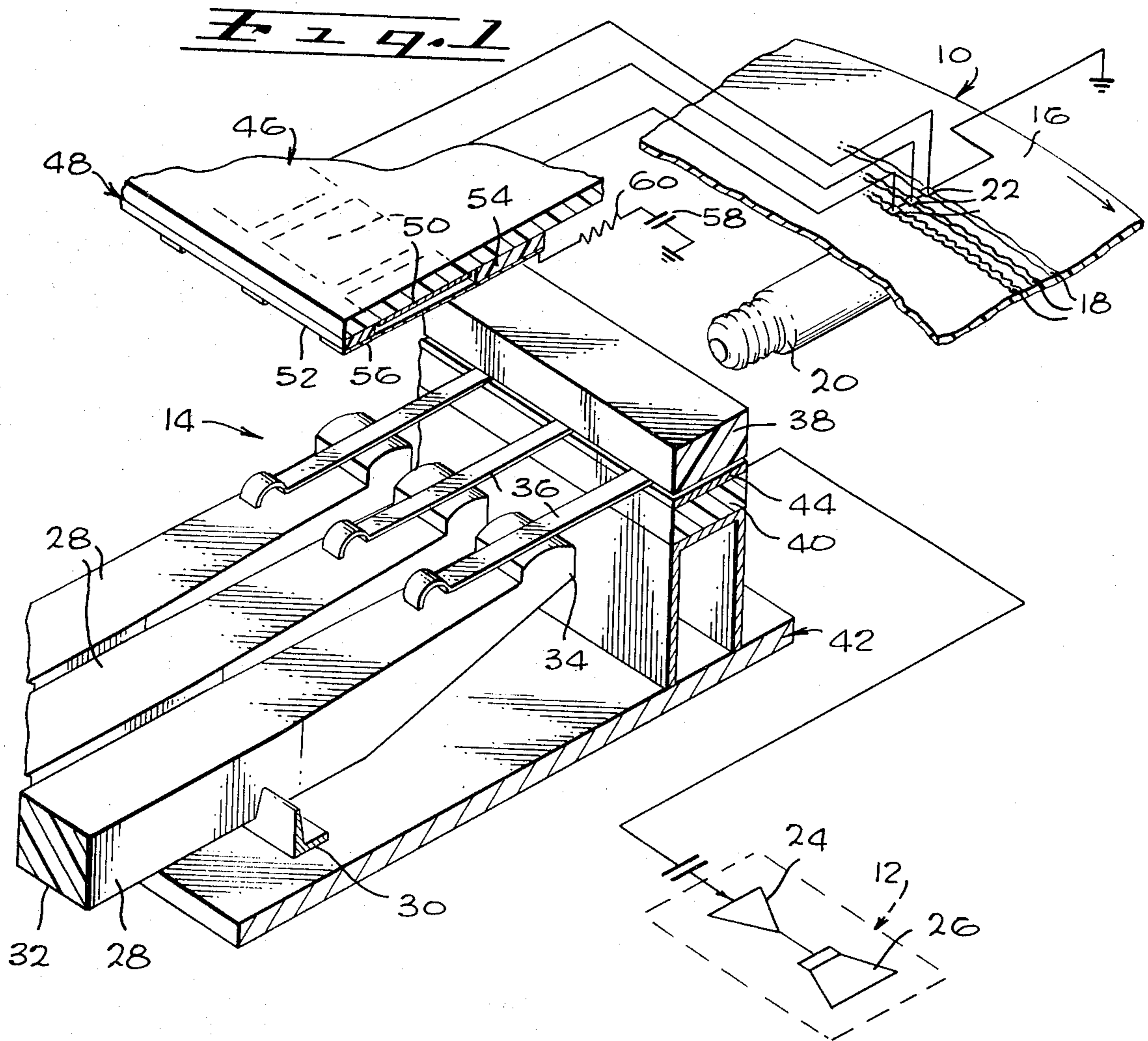

INVENTOR.
STANLEY CUTLER
BY
David L. Orrin
ATTORNEY

Fig. 2

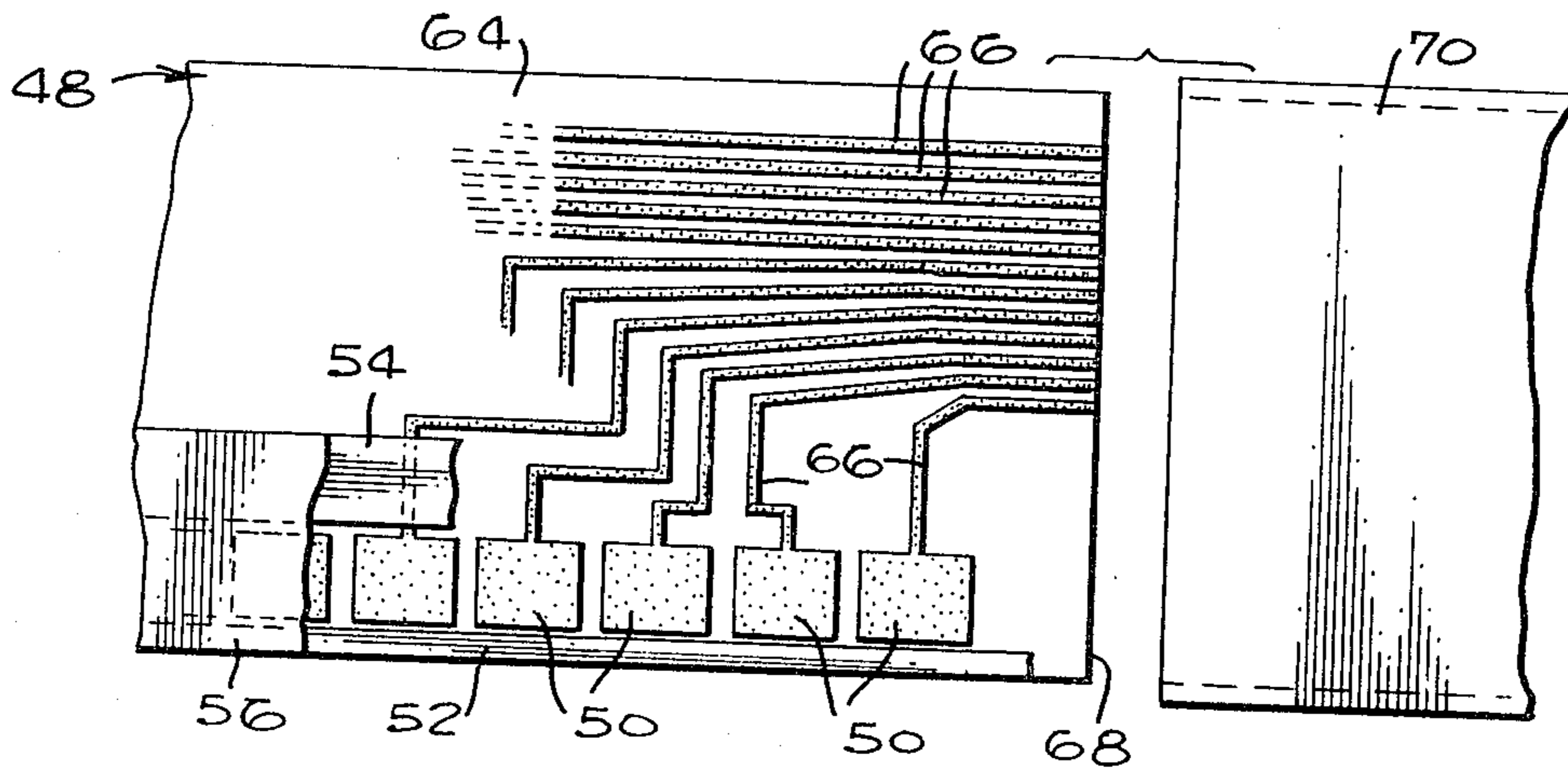
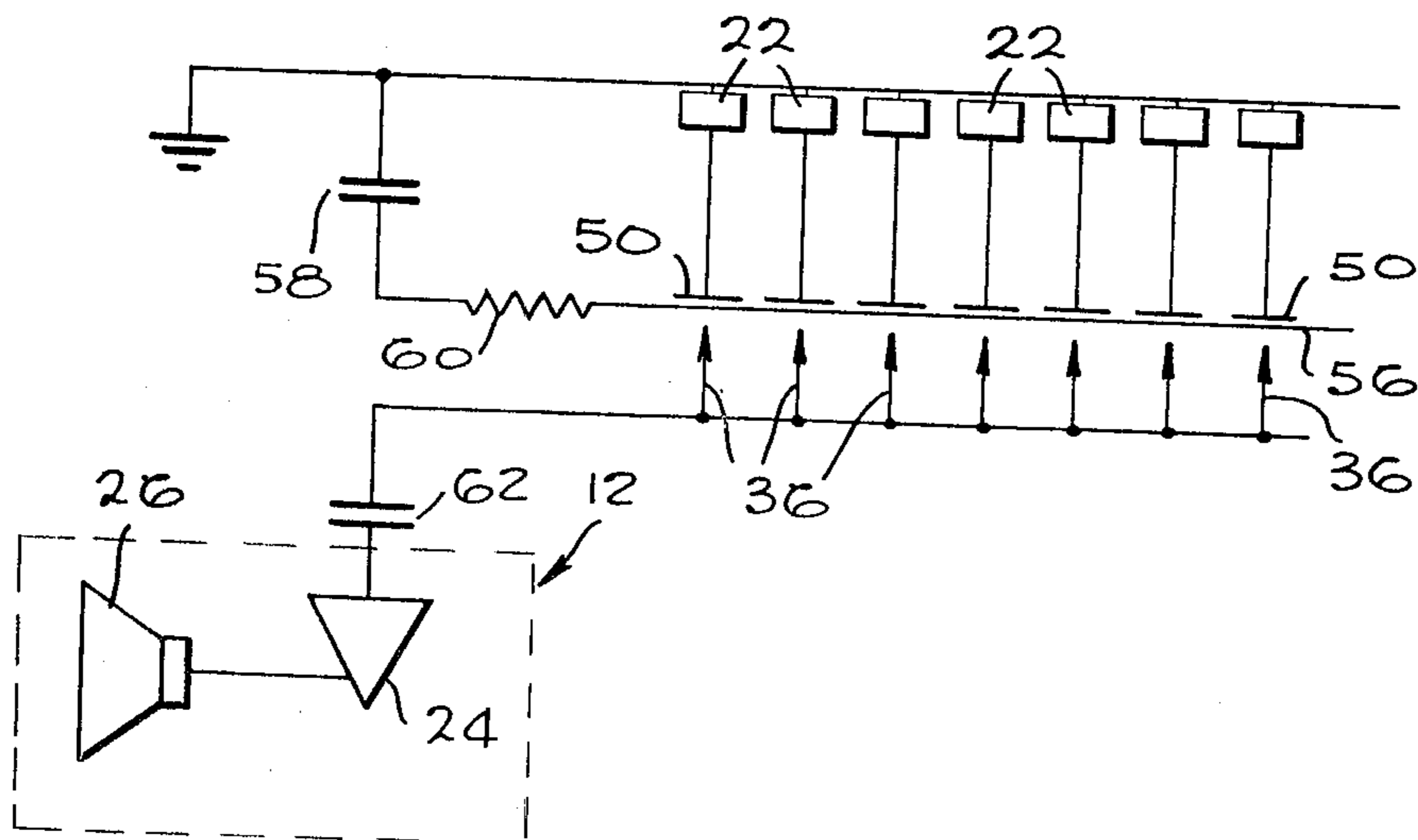

Fig. 3



INVENTOR.
STANLEY CUTLER
BY *Edward L. Quinn*
ATTORNEY

ORGAN KEYBOARD SWITCHING SYSTEM

BACKGROUND OF THE INVENTION

1. Field of the Invention

This invention relates to electronic organs.

2. Description of the Prior Art

Electronic organs require a row of switches operated by a piano-like keyboard, to selectively connect the tone generators to the speaker assembly (which includes an amplifier and loudspeaker). One type of switching apparatus includes a row of resilient contact members which are deflected upwardly to contact a bus bar, each switch member connected to a different tone generator and the bus bar being connected to the speaker assembly. The bus bar can be constructed of copper or other metal, or of a conductive plastic such as polyvinylchloride (PVC) material impregnated with carbon to make it partially conductive. Such switching arrangements involve considerable labor in their production, inasmuch as a separate wire connection must be made between each resilient switch member and a tone generator. In addition, mechanical noise is produced as a switch member hits the bus bar, even in the case of a PVC bus bar. Furthermore, electrical noise in the form of a click or pop is often heard due to the electrical transient resulting from the fact that a switch member may have an appreciable voltage on it at the instant it makes contact with the bus bar. A switching arrangement which was simple to construct and which minimized mechanical and electrical noise would enable electronic organs of superior operating characteristics to be produced at lower cost.

OBJECTS AND SUMMARY OF THE INVENTION

An object of the present invention is to provide a switching arrangement for electronic organs, which is economical to produce and install.

Another object is to provide a switching arrangement for electronic organs, which minimizes noises which can occur during the closing of switches.

In accordance with one embodiment of the present invention, a switch assembly is provided for electronic organs, which is simple and economical to construct and install and which minimizes noises which can occur during operation of the switches. The assembly includes a row of resilient switch members which can be upwardly deflected against a contact assembly by operation of the organ keys. The contact assembly includes a circuit board with numerous conductive pads arranged in a row above the row of switch members. A pair of insulating spacer members extend along either side of the row of circuit board pads, and an intermediate strip constructed of flexible conductive plastic is fastened to the spacer strips so it lies spaced slightly below the row of pads. When an organ key is depressed, a corresponding switch member is upwardly deflected against a region of the intermediate plastic strip. The region of plastic strip is pushed against a conductive pad which lies immediately above it, to thereby close the switch.

The use of a circuit board with numerous conductive pads minimizes the amount of labor required in making electrical connections. The circuit board can be mass produced at low cost, and can be made to terminate in a row of strips so that it can be installed by plugging one end of it into a connector in the organ. The use of a flexible intermediate strip reduces mechanical noise because much of the kinetic energy of the upwardly moving switch member is absorbed in deflecting the strip, and because the strip can dampen vibrations of the switch member before contact is made with a circuit board pad. Electrical noise in the form of clicks or pops is minimized where an intermediate strip is used which undergoes a decrease in resistance during the first portion of compression thereof, as can be the case of a strip constructed of polyvinylchloride impregnated with carbon. The intermediate strip can be connected through a capacitor to ground so that it is charged up to any DC bias of the tone generators when the

first few notes are played on the organ. Thereafter, transients due to DC bias of the tone generator are substantially eliminated.

The novel features of the invention are set forth with particularity in the appended claims. The invention will be best understood from the following description when read in conjunction with the accompanying drawings.

BRIEF DESCRIPTION OF THE DRAWINGS

FIG. 1 is a partial perspective view of an organ with a keyboard switching assembly constructed in accordance with the present invention;

FIG. 2 is a sectional side view of the apparatus of FIG. 1;

FIG. 2a is a view similar to FIG. 2, but with the switch in a closed state;

FIG. 3 is a partial schematic view of the apparatus of FIG. 1;

FIG. 4 is a partial bottom view of the circuit board of the apparatus of FIG. 1.

DESCRIPTION OF THE PREFERRED EMBODIMENTS

FIG. 1 illustrates an organ constructed in accordance with the invention, which includes tone generator apparatus 10 for generating electrical signals representing musical tones, speaker apparatus 12 for converting the signals to audible sounds, and switching apparatus 14 for enabling a musician to select the tones to be played, or sounded. The tone generator apparatus 10 includes a rotatable optical disc record 16 which has numerous concentric tracks 18 defined by the transparent regions between opaque borders. A lamp 20 directs light through the tracks 18 as the disc rotates, and a series of photocells 22 sense the light which passes through the tracks. The photocells may be considered as tone generators, inasmuch as they generate electrical signals representing the tones recorded on the tracks 18. The speaker apparatus or means 12 is shown as including an amplifier 24 and loudspeaker 26, although it may include devices such as tremolo and swell controls and the like. The switching apparatus 14 includes a piano-type keyboard with keys 28 that are depressed by a musician to select the tones to be played.

Each key 28 of the switching apparatus 14 is pivotally mounted on a pivot bar 30, so that when a musician depresses a forward part 32 of the key, a rearward part 34 moves upwardly. A row of switch members 36 extend along the rearward end of the keys so that depression of a key deflects a corresponding switch member. The switch members 36 are constructed of a resilient electrically conductive material such as beryllium copper, and they are held in place between a pair of bars 38, 40 that are mounted on the housing 42 of the organ. A bus bar 44 is also provided which electrically connects all of the switch members 36 together, and the bus bar is connected to the speaker arrangement 12.

A contact assembly 46 is located above the switch members 36. The contact assembly 46 includes a circuit board 48 which has a row of conductive pads 50 extending parallel to the row of switch members 36. Each pad 50 is connected to a different tone generator 22, so that when a switch member 36 is coupled to a pad 50, a signal from one of the tone generators passes through the switching arrangement into the speaker arrangement 12. It would be possible to have each switch member 36 directly contact a corresponding pad 50 to complete the circuit from a tone generator to the speaker. However, this could produce a clicking sound when a switch member 36 contacts a metallic pad 50, particularly where a musician operated the key rapidly, and could also produce undesirable electrical transients.

Several undesirable transient effects could result if the switch members 36 directly contacted the circuit board pads 50. In many cases, the suddenly deflected switch member 36 would still be vibrating as it contacted a pad 50, and cause several makes and breaks before a firm connection was

established. In the case of tone generators which include the photocells 22 that sense a light beam of varying amplitude, there is an appreciable DC component in the signal, and a "popping" sound can be produced when the DC bias is suddenly applied to the speaker. There is also an AC transient signal that can produce a popping sound if the switch member 36 contacts a pad at an instant when the AC component of the tone generator signal is appreciable. The contact assembly 46 is constructed to minimize mechanical and electrical noise, using a construction which adds a minimal cost to the organ.

As best shown in FIG. 2, the contact assembly 46 includes a pair of insulative spacer strips 52, 54 which extend along either side of the row of pads 50 on the circuit board, and an intermediate conductive strip 56 which extends between the two spacer strips 52, 54. The intermediate strip 56 is constructed of a flexible material of moderate resistance, and preferably of an elastic material such as a soft conductive rubber or plastic. A polyvinylchloride (PVC) material, impregnated with carbon to make it partially conductive, has been found suitable for this purpose. Such a material largely resembles rubberized electrician's tape, that is, it is easily deflected and deformed, or stretched, as compared to steel or copper material of the same thickness, but returns to its original shape if not excessively deflected. The readiness to local deformation and low spring constant for a strip of given thickness or unit weight, allows it to readily deaden vibrations. Another embodiment of the invention employs a soft rubber impregnated with particles of a conductive material such as carbon.

The spacers 52, 54 hold the intermediate strip 56 so that it extends at a position spaced a small distance below the row of pads 50 on the circuit board. When a key 28 deflects a switch member 36 upwardly, the end 36E of the switch member presses upwardly against the intermediate strip 56 at a location between the spacers 52, 54. The switch member end 36E deflects a region of the intermediate strip 56 against the pad 50 that lies immediately above it. Only the region of the intermediate strip 56 that is contacted by the switch member 36 is substantially deflected (it and surrounding portions are stretched), so only that region of the intermediate strip contacts a pad. When a musician releases the key and the switch member 36 springs downwardly to its original position, the deflected and stretched portion of the intermediate strip 56 contracts back to its original position wherein it is spaced from the pad 50 that lies immediately above it.

The intermediate strip 56 greatly reduces mechanical noise because very little noise is produced when a switch member hits the relatively soft intermediate strip, or when a region of the strip hits a conductive pad 50. Even if a small square piece of the PVC material were attached directly to the pad 50, mechanical noise would be reduced when a switch member 36 hits it. However, the fact that the intermediate strip is spaced from the pad and must be stretched and deflected by the switch member means that there is a more gradual application of pressure by the switch member 36, and mechanical noise is reduced to an even smaller level. In the same manner, the intermediate strip damps vibrations of the switch member 36 before contact is made with a pad 50, so that no breaks in the contact are made once contact is established, and therefore this source of noise is eliminated.

The relatively soft material of the intermediate strip 56 undergoes a decrease in resistance during the first portion of compression. Accordingly, signal transients are reduced somewhat. For example, if a tone generator signal has an appreciable value at the instant when the intermediate strip touches a conductive pad 50, the signal strength reaching the speaker apparatus 12 will be somewhat attenuated until the fraction of a second later when the intermediate strip region is pressed hard against the pad and a larger area of the intermediate strip is contacting the pad. Thus, there is a minimization of the sudden rise in applied voltage as contact is established.

In order to achieve an appreciable reduction in signal transients due to change in resistance of the intermediate strip as contact is made, the initial electrical resistance of the intermediate strip region must be large as compared to the impedance of the tone generator 22 and the impedance of the speaker apparatus 12. In one organ, each photocell generator 22 had an internal and output impedance of about 50k ohms and the amplifier of the speaker apparatus had an input impedance of about 5k ohms. The initial resistance, or impedance of the intermediate strip region should be at least 50k ohms to greatly reduce the initial signal. The final impedance of the intermediate strip region should be low compared to the impedance of the tone generator or speaker arrangement, e.g., less than 5k ohms, so that a maximum portion of the signal reaches the speaker arrangement. Carbon-impregnated PVC strips have been constructed and used, whose impedance decreases from over 50k ohms to less than 1k ohms.

As mentioned above, certain types of tone generators, such as those which employ photocells that sense a light beam of variable intensity, generate an appreciable DC signal. The DC bias can produce large transients that create popping sounds when a key is first depressed. To minimize the effects of DC bias, the intermediate strip 56 is connected through a capacitor 58 and high resistance 60 to ground, as shown in FIG. 3. This is the same ground potential to which each photocell 22 is connected (each photocell 22 has one side grounded and the other side connected to a pad 50). In addition, a series capacitor 62 is connected in series with the speaker assembly 12. Each of the tone tracks of the record disc have approximately the same average width, so that each of the photocells 22 carries approximately the same DC bias. When the organ is first turned on and a key is held down for a few seconds or several keys are played in succession, the capacitor 58 charges up to the DC bias of the photocells 22. In addition, the capacitor 62 leading to the speaker assembly charges up to the DC bias of the photocells. Thereafter, when a switch member 36 moves against the intermediate strip 56 and then against a pad 50, no transients are created because of DC bias, because the intermediate strip 56 has the same DC potential as that of the switch member 36 and of the pads 50. It may be noted that there is stray capacitance between the conductive pads 50 and the intermediate strip 56, which results in a small signal from all of the tone generators 22 appearing on the intermediate strip. However, this "hash" or noise is not noticeable because it does not reach the speaker apparatus 12 until at least one key is depressed to select a tone generator, and then it is masked by the much greater signal from the selected tone generator.

FIG. 4 illustrates the arrangement of the pads 50 on the circuit board 48. The circuit board includes a backing board 64 of insulative material, and includes numerous conductive strips 66. Each conductive strip 66 is integral with one of the pads 50 and extends to one end 68 of the circuit board. The fact that all of the conductive strips 66 terminate at one end 68 of the board enables connection of the strips, and therefore of the pads 50, through the use of a plug-type connector 70. The circuit board 48 can be constructed in a conventional manner, as by adhesively attaching a sheet of copper to the backing board 64, and etching away regions of the copper as determined by a mask. Thus, the positioning of the numerous pads 50 and of the connecting strips 66 that lead to one end of the circuit board, can be accomplished at minimal cost in mass production. After the circuit board is constructed, the two spacer strips 52, 54 can be applied with an adhesive, and the intermediate strip 56 can be applied over the spacer strips, also by use of an adhesive. It may be noted from FIG. 2, that one of the spacer strips 54 is thicker than the other 52, so that the intermediate strip 56 extends at an incline with respect to the pads 50. It has been found that this arrangement, with the switch member 36 depressing a region of the intermediate strip closer to the thicker spacer, allows for a more rapid return of the intermediate strip when the switch member 36 springs to its original position. This is particularly important if

the musician has held down the key for more than a few seconds, because the PVC material will temporarily retain the shape to which it has been stretched, and it is then important that the strip return as quickly as possible to its original shape.

Thus, the invention provides an organ switching arrangement which minimizes noises that might otherwise be produced at the instant when switches are closed, and which enables the mass production of apparatus with many switches at low cost. Noise is minimized by the use of an intermediate conductive member between two switch contacts, which is originally spaced from both contacts but which touches the contacts in succession as the switch is closed. The intermediate member is preferably constructed of a soft flexible material, such as soft conductive plastic, a conductive rubber, or other elastomeric material. Manufacturing costs are minimized by utilizing a strip-shaped intermediate member that extends between two rows of contacts (the switch members 36 and pads 50), and by constructing one row of contacts as a circuit board. This construction minimizes the number of individual parts that must be interconnected.

Although particular embodiments of the invention have been described and illustrated herein, it is recognized that modifications and variations may readily occur to those skilled in the art and, consequently, it is intended that the claims be interpreted to cover such modifications and equivalents.

What is claimed is:

1. In an electronic organ which includes speaker means, a plurality of tone generator means, and a plurality of manually operable keys for selecting different tones, the improvement comprising:

a first electrically conductive element and a second element spaced from said first element, said second elements positioned for deflection by a key to move towards said first element;

an intermediate member of an electrically conductive material which is more easily deformed than the material of either of said elements;

supporting means for supporting said intermediate member between said elements and spaced from each of them, so that when said second element is deflected by a key towards the said first element it engages and deforms a contact region of said intermediate member against said first element, said supporting means holding said intermediate member so it does not move with said second element until said second element is deflected and engages said contact region of said intermediate member;

means for carrying electrical signals from said tone generator means to said first element; and

means for carrying signals that pass between said first element, intermediate member, and said second element to said speaker means.

2. The improvement described in claim 1 including:

a plurality of additional first elements;

and

a plurality of additional second elements, said first elements arranged in a row and said second elements arranged in another row, so that a second element lies opposite and spaced from each first element; and wherein

said intermediate member includes a strip of stretchable material extending between said rows of elements; and said supporting means supports side portions of said strip so that said strip is taut.

3. An organ keyboard arrangement comprising:

means defining a set of contact regions arranged in a row;

a strip of stretchable conductive elastic material;

spacer means holding said strip of elastic material so it extends parallel to but spaced from said row of contact regions and in a taut condition; and

a plurality of moveable members positioned for individual manually controlled movement to press and stretchably deflect different preselected regions of said strip of elastic material against corresponding contact regions.

4. The improvement described in claim 3 wherein:

said moveable members are positioned to lie spaced from said strip of material prior to manually controllable movement, so that said members must move a distance before they engage said strip.

5. An organ keyboard comprising:

a housing;

a row of resilient contact members, each having a first end mounted on said housing and a second end which is free to deflect;

a backing board of electrically insulative material mounted on said housing and spaced from said free ends of said resilient contact members;

a plurality of electrical contacts mounted on said backing board and arranged in a row parallel to said row of resilient contact members;

means defining a pair of insulative spacer strip portions on said board, said spacer strip portions extending along opposite sides of said row of electrical contacts thereon;

an intermediate strip of a conductive, readily deformable material disposed on said spacer strips, so it is maintained spaced from said row of electrical contacts and spaced from said resilient contact members when they are undeflected; and

a row of manually operable keys pivotally mounted on said housing for deflecting said resilient contact members against regions of said intermediate strip lying between said spacers, to deflect said regions against said contacts on said board.

6. The organ described in claim 5 wherein:

one of said spacer strips is thicker than the other.

7. In an electronic organ which includes speaker means, tone generator means which generate a predetermined direct current bias, and a manually operable key, the improvement comprising:

first and second spaced electrical contacts respectively coupled to said tone generator means and to said speaker means, said second contacts positioned for deflection by a key to move towards said second contacts;

an intermediate member of a material which is more easily deformed than the material of either of said contacts, positioned between said contacts and spaced from each of them, so that when said second contacts are deflected by a key towards said first contacts, it deforms said intermediate member against said first contacts; and

a capacitor electrically connected between said intermediate member and the ground of said generators to tend to maintain it at said predetermined direct current bias after it has engaged said first contact.

8. In an electronic organ which includes speaker means, a plurality of tone generator means which each generate a predetermined DC bias and which each have a first terminal coupled to a source of predetermined potential and a second terminal, and a plurality of manually operable keys for selecting different tones, the improvement comprising:

a first set of contact regions arranged in a row;

a strip of conductive elastic material;

spacer means holding said strip of elastic material so it extends parallel to but spaced from said row of contact regions;

a plurality of contact members defining a second set of contact regions, said contact members positioned for individual movement by different manually operable keys, so their contact regions press and deflect different preselected regions of said strip of elastic material against corresponding contact regions of said first set;

first means for coupling the contact regions of said second set of contact regions to the second terminals of different of said tone generator means;

second means for coupling the contact regions of said second set of contact regions to said speaker means; and

a capacitor coupling said strip of elastic material to said source of predetermined potential.

* * * * *