

May 10, 1966

H. C. CHAMBERLIN

3,250,847

MUSICAL INSTRUMENT WITH RECORD TYPE TONE GENERATOR

Original Filed July 5, 1960

3 Sheets-Sheet 1

Fig. 1.

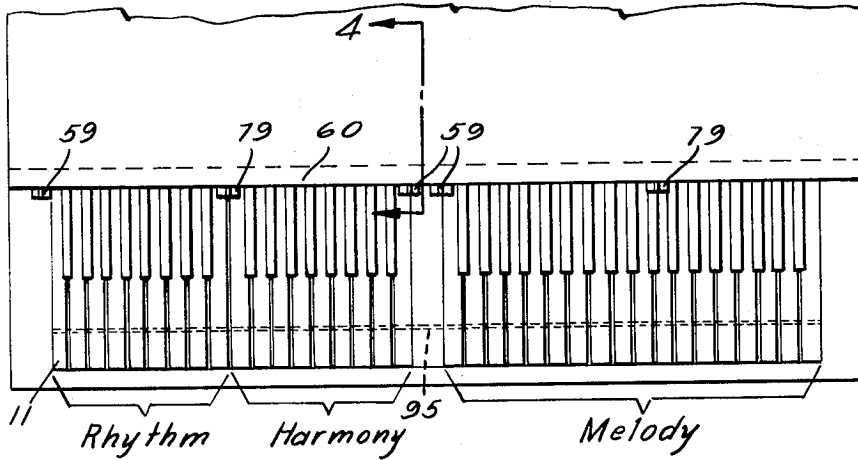
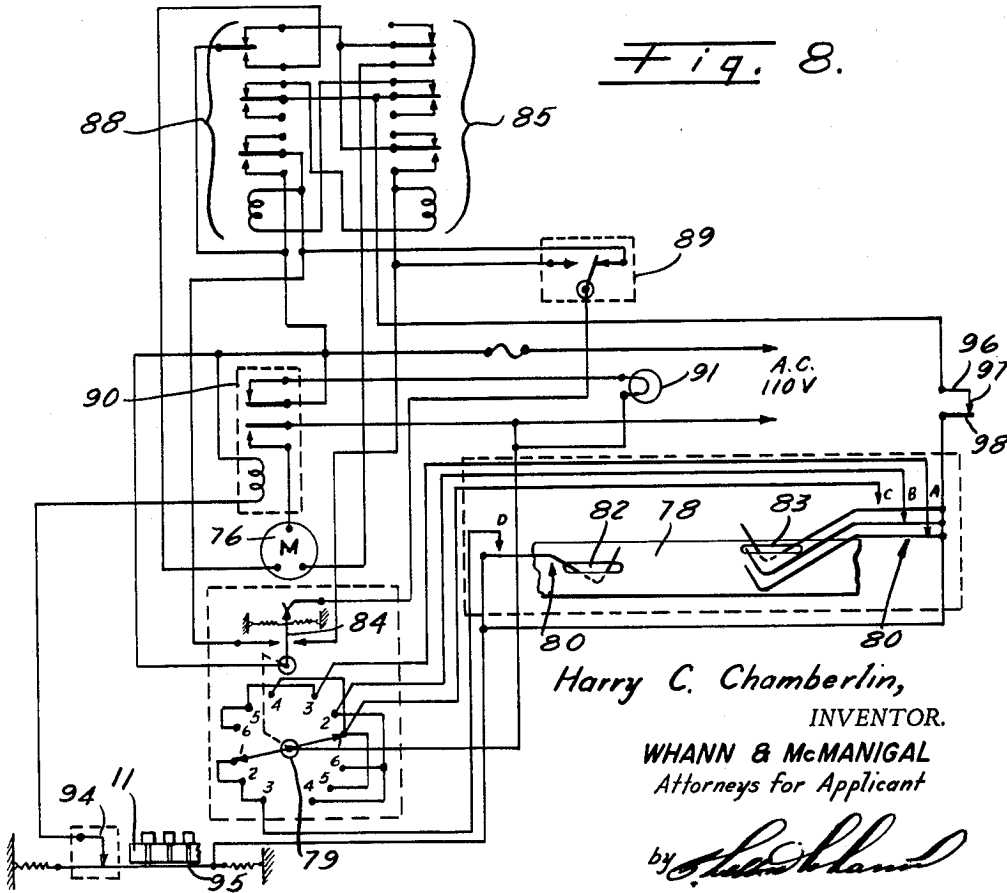

Fig. 8.



Harry C. Chamberlin,
INVENTOR.

WHANN & McMANIGAL
Attorneys for Applicant

by *[Signature]*

May 10, 1966

H. C. CHAMBERLIN

3,250,847

MUSICAL INSTRUMENT WITH RECORD TYPE TONE GENERATOR

Original Filed July 5, 1960

3 Sheets-Sheet 2

Fig. 2.

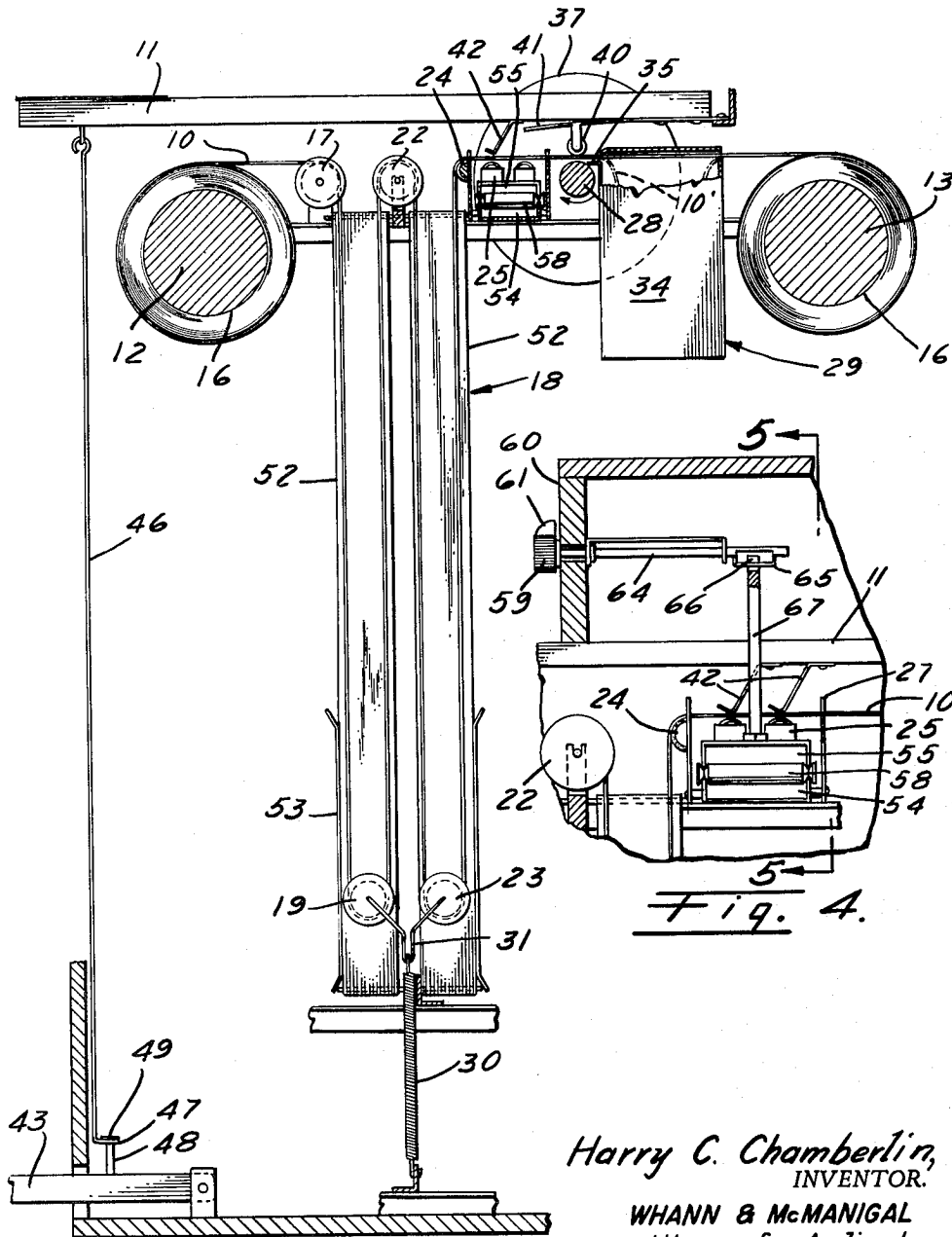

Harry C. Chamberlin,
INVENTOR.

WHANN & McMANIGAL
Attorneys for Applicant

by *Shubland*

May 10, 1966

H. C. CHAMBERLIN

3,250,847

MUSICAL INSTRUMENT WITH RECORD TYPE TONE GENERATOR

Original Filed July 5, 1960

3 Sheets-Sheet 3

Fig. 7.

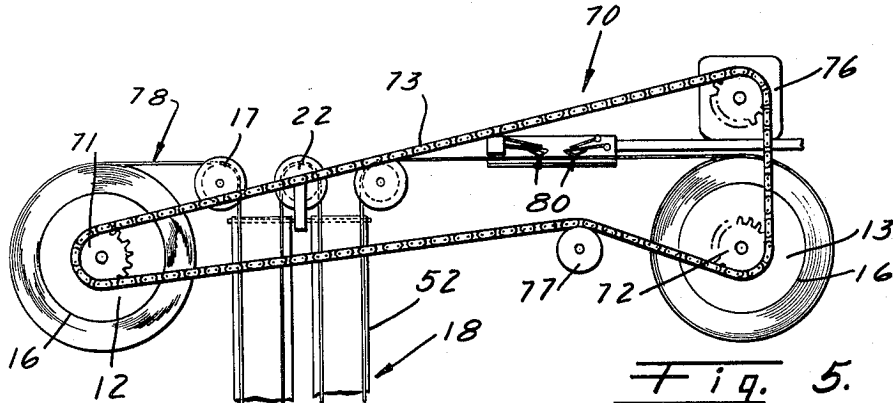

Fig. 5.

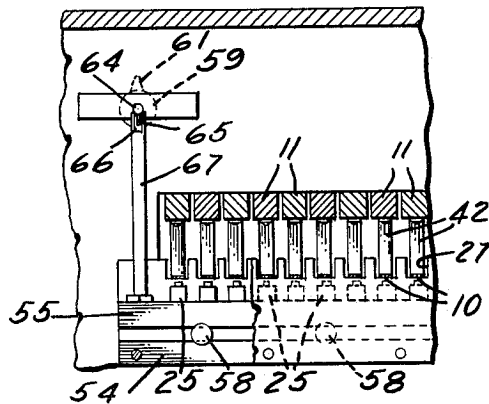

Fig. 6.

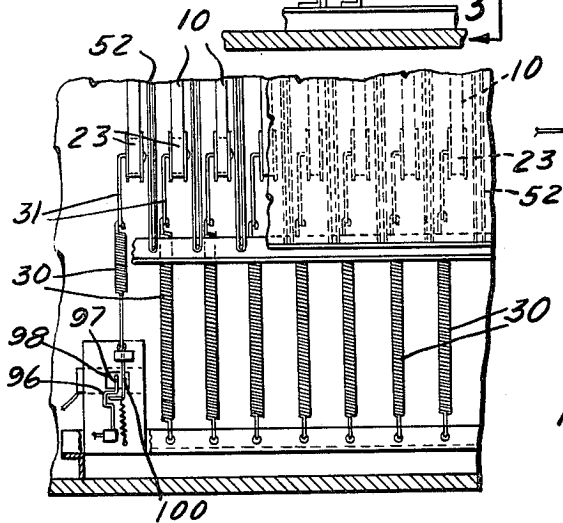
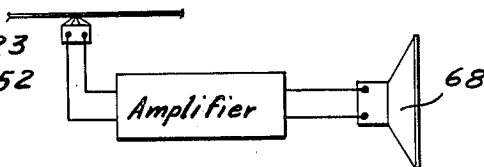

Fig. 3.



Harry C. Chamberlin,
INVENTOR.

WHANN & McMANIGAL
Attorneys for Applicant

by *Sheldon Whann*

1

3,250,847

**MUSICAL INSTRUMENT WITH RECORD TYPE
TONE GENERATOR**

Harry C. Chamberlin, Upland, Calif., assignor to Chamberlin Instrument Company, Inc., Upland, Calif.
Continuation of application Ser. No. 40,701, July 5, 1960.
This application Feb. 4, 1965, Ser. No. 432,445
6 Claims. (Cl. 84-1.28)

This application is a continuation of my prior application, Serial No. 40,701, filed on July 5, 1960, for "Musical Instrument."

This invention relates to a musical instrument and more particularly to a musical instrument which reproduces, according to the action of the player, previously recorded rhythm and harmony chords and solo notes concurrently to produce a complete musical composition.

The present invention provides a new type of musical instrument and embraces improvements in the devices disclosed in my United States Letters Patent No. 2,910,298, issued October 27, 1959, for Sound Reproducing System, and No. 2,940,351, issued June 14, 1960, for Magnetic Tape Sound Reproducing Musical Instrument.

The present invention has three parts, each of which includes a multiplicity of magnetic tapes having predetermined notes or chords recorded thereon and which may be played by the operation of keys as required to reproduce a musical composition and so as to sound as if it were being played by a band or an orchestra.

It is an object of the present invention to provide a musical instrument on which a musical composition can be played from a plurality of magnetic tapes, each having thereon chords and/or notes recorded during the playing of musical instruments.

It is another object of the invention to provide a musical instrument having a rhythm part, a harmony part and a melody part. That is, by depressing selected keys in the said parts, a rhythm, a harmony and the melody of a complete musical composition can be played.

The rhythm part is comprised of a multiplicity of magnetic tapes having recordings of repeated chords thereon from a plurality of instruments, such as banjos, guitars, bass viols and drums, the tapes being arranged to be played in a tempo determined by the repetition rate of the recorded chords and in the same key as required for a particular musical composition.

The harmony or accompaniment group of tapes has recorded chords thereon made by instruments, such as the saxophone, trombone, and celeste, and are arranged to be played with the same tempo and in the same key as corresponding rhythm parts. The actuation of one key in the harmony group may, for example, produce a complete ten-finger chord to match a rhythm that is being played at that time. In other words, one key actuated can play chords that require two hands of any number of musicians to produce.

The melody part is comprised of a multiplicity of tapes for reproducing musical notes from G to F, for example, each one being recorded by a plurality of the same instrument or the human voice and may be played to produce chords to provide the melody in all of the musical keys. In the melody group the tempo is produced to match that provided by the rhythm and harmony groups by the timing of the depression of various actuating keys by the operator.

It is still another object of the present invention to provide a musical instrument having a multiplicity of recordings on magnetic tapes arranged so that a rhythm part and a harmony part of a musical composition can be played in the same key and the same tempo simultaneously by depressing one actuating key in each part.

It is a further object of the present invention to pro-

2

vide a musical instrument for reproducing solo notes arranged chromatically from G to F, for example, on the keyboard. Each of said notes are recorded on tapes for actuation by piano type keys and are playable, for example, for eight seconds depending on the length of the recorded tape. The keys, when actuated according to simple instructions, produce a desired melody.

It is another object of the invention to provide a musical instrument in which magnetic tapes used have three tracks and each track has six adjacent or consecutive sections of a specific recording, each of the six being playable separately on each tape by the depression of a key. The tapes in the rhythm and harmony parts are transportable together so that the same sections of each are playable at the same time. The arrangement of the tapes for playing is determined by the tracks selected; that is, to play the same rhythm in the same key in both harmony and rhythm groups, the same section and the same track in each group are positioned to be playable together. The melody group is transported separately and in the six sections there are recordings of eighteen different solo instruments, each of the track of each section having a separate group of the same instruments and the tracks in each section being arranged chromatically from G to F.

It is a further object of the present invention to provide a method for playing a musical composition by which individual actuating keys may be operated to actuate magnetic tapes by which the rhythm and harmony parts, each having been previously recorded as chords, the rhythm chords having been repetitively recorded in a definite tempo and key, may be played and by which the solo part, having been recorded as individual notes, may be reproduced as a melody to match the tempo and key of the rhythm and harmony parts.

It is still another object of the present invention to provide a musical instrument in which the harmony of a musical composition may be produced in the same chords as the rhythm part whereby each of seventeen harmony actuating keys, for example, when depressed, complete a ten-finger chord to match the rhythm being played on a corresponding one of seventeen rhythm actuating keys.

It is a further object of the invention to provide a means of transporting the tapes longitudinally by consecutive sections so as to position them so that they will produce in the proper timing.

It is another object of the invention to provide a means of instantaneously actuating a tape to reproduce sound when a key is depressed and to return the tape substantially instantaneously to its reservoir starting position after the key has been released.

Further objects and advantageous of the invention may be brought out in the following part of the specification wherein some small details have been recited for the purpose of providing a complete disclosure; without intending to limit the scope of the invention which is defined by the accompanying claims.

Referring to the accompanying drawings which are for illustrative purposes only:

FIG. 1 is a fragmentary plan view illustrating the keyboard of a musical instrument according to the present invention;

FIG. 2 is a side elevational view illustrating one magnetic tape and its operating key;

FIG. 3 is a fragmentary rear view illustrating the arrangement of the magnetic tapes and taken as indicated by the line 3-3 of FIG. 7;

FIG. 4 is a fragmentary side view taken as indicated along the line 4-4 of FIG. 1;

FIG. 5 is a rear elevational view taken along the line 5-5 as indicated in FIG. 4;

FIG. 6 illustrates the equipment for taking the sound off the tape and reproducing it;

3

FIG. 7 is a side elevational view of a tape transporting system; and

FIG. 8 is a diagrammatic view of the electrical circuit for operating a tape transporting system.

Referring again to the drawings, in FIG. 1 there is a view of a keyboard of a musical instrument, according to the present invention, shown to be in the form of a spinet. There are three groups of keys shown diagrammatically, namely, those which play the rhythm portion of a musical composition, those which play the harmony or accompaniment and those on which the melody is played.

Each key when depressed functions to actuate a magnetic tape so that the sounds recorded on the tape are reproduced. Each tape has three tracks arranged side-by-side and each track is divided into six consecutive sections, for example, so that for each tape there are eighteen different playing position by which the recordings thereon may be reproduced by the depression of one key.

In the rhythm part the tapes have recordings of repeated chords from groups of various instruments, such as the banjo, guitar, bass viol and drums; the rate at which the recorded chords repeat determine the tempo. In the harmony or accompaniment part of the tapes have recordings of groups of instruments, such as the saxophone, trombone, each playing in the same tempo and key as on corresponding recordings on the rhythm producing tapes. In the melody part, one note is recorded on each track in each section of the tapes playable at the same time ranging from G chromatically to F, the notes having been produced by a plurality of like instruments or the human voice to provide means by which desired melody chords may be produced in the solo form. Thus, when one or more keys in the rhythm, harmony and melody parts are played concurrently in accordance with simple instructions, indicating the proper keys to be played by number, a complete musical composition can be played.

As indicated in FIGS. 2, 3, and 5, the individual tapes 10 are in side by side relationship, corresponding to the keys, so that the downward movement of a key actuates a recorded tape. In FIG. 2, one tape 10 and its actuating or playing key 11 are illustrated schematically. To store the various sections of tape, the device has two front drums 12, only one shown, and two rear drums 13, only one shown, arranged in spaced parallel relationship transverse to the keys. On one set of front and rear drums, the tapes having the rhythm and harmony recordings thereon, are stored and the other set of drums, in axial alignment with the first set, store the tapes having the melody notes thereon. Each drum has a plurality of circumferential channels 16 forming spools on which the opposite ends of the tapes 10 are fastened and wound. Each tape is divided into six longitudinal sections, for example, and each section may be brought into sound reproducing position in the device by suitable rotation of the sound reproducing tape storage drums 12 and 13.

From the front spool 12, each tape extends horizontally to an idler roller 17 downwardly into a reservoir, generally designated as 18, and in which the tape is in position to be played; that is, to have its recorded sound reproduced. The tape in the reservoir is in four lengths, that is, it extends downwardly from idler 17 to retracting pulley 19 and upwardly from pulley 19 to idler 22. From idler 22, it again extends downwardly to retracting pulley 23 to a small roller or smooth curved surface 24. It then extends horizontally rearwardly over the spaced magnetic pickup heads 25, one of which is required for each tape. As may be best seen in FIGS. 4 and 5, the tapes are guided as they pass over the heads by channel members 27.

Rearwardly of the pickup heads, the tape extends over a driving roller 28 through a receiver 29 and on to drum 13. The drums 12 and 13 are held against rotation and the magnetic tape 10 is held taut between the drums by

4

the retracting rollers 19 and 23 which are urged downwardly by a coil spring 30 having its upper end attached to an extension 31 of the axles of the pulleys 19 and 23, and being secured at its lower end to the frame of the device.

Each tape receiver 29 into which the tape travels when it is played comprises a flat container having opposite side walls 34, only one of which is shown, spaced apart a distance slightly greater than the width of the tape 10. The upper portion of the receiver 29 is formed so as to provide an inlet lip 35 close to the top portion of the drive roller 28 and at the rear end of the receiver is an opening 36 through which the tape passes when it is transported on the drums.

When the musical instrument is ready for playing, a driving roller 28 is in continuous rotation as driven by a pulley 37, in turn driven by an unshown motor. For each tape 10 having recordings thereon, there is a roller 40 adapted to deflect the tape downwardly into frictional engagement with the rotating driving roller 28, with the result that the tape will be moved rearwardly or rightwardly in FIG. 2, pulling it upwardly from the reservoir 18 and feeding it through the inlet lip 35 into the interior of the receiver 29 wherein the tape folds back and forth in convolutions one on top of the other, as indicated in part by the phantom line 10'. This operation occurs when a tape is played and the roller 40 is depressed by means of a leaf spring 41 supporting a playing key 11. At the same time the key is depressed, a spring 42 forces the tape 10 and at least one of its tracks into contact with a magnetic pickup head 25. When the key is released, and the roller 40 is lifted so as to disengage the tape 10 from the drive roller 28, the tape portion having been played and moved into the receiver is substantially instantaneously pulled therefrom and returned to reservoir 18 by the tape retracting means, formed by the two pulleys 19 and 23 and the spring 30. The high speed return to the reservoir 18 of the tape from within the receiver is accomplished because the tape in the latter is without restraint therein. The arrangement of four spaced lengths of tape in the reservoir 18 permits the movement of four times as much tape out of the reservoir as the distance of the stretching movement of the spring 30. The particular embodiment permits the playing of the chords or notes on each tape at a rate of 7½ inches per second for eight seconds which is a considerable longer period of time than necessary for the playing of individual chords and notes of most musical compositions. Accordingly, any recorded note, a chord, or a repetitively recorded rhythm chord can only be reproduced or played for eight seconds.

The key 11, as shown in FIG. 2, may also be operated by a foot pedal 43. The key 11 has one end of a wire 46 connected thereto, the lower end of the wire having a horizontal loop 47 which is slidably engaged on a pin 48 in the foot pedal, the loop being held on the pin by head 49. The foot pedal arrangement need only be attached to the third set of keys on the left in FIG. 1, or the rhythm group, to provide a means to depress the keys in the latter group when the two hands are engaged in playing the harmony and melody. By this arrangement the leaf spring 41 holds the foot pedal, as well as the key upwardly in its nonplaying position. If, however, the key is played by hand, the loop 47 permits the wire to move downwardly on the pin 48 without effecting the movement of the foot pedal.

Each of the tapes 10 are spaced between vertical plastic strips 52, suitably supported at their ends by frame members, as shown in FIGS. 2 and 3, and extending transversely in relation to the tapes at their lower portions is an upwardly opening U-shaped frame member 53, which together with the plastic strips holds the tapes 10 and the lower pulleys 19 and 23 in proper alignment.

Referring now to FIGS. 2, 4, and 5, the pickup heads 25 one for each tape 10, are supported on a lower sup-

5

port member 54, in turn supported on a frame member of the device, and which extends transversely with respect to the tape and the keys. Directly under the heads is an upper support member 55 which is supported on rollers 58 so as to be slidably engageable with respect to the fixed lower support 54. Thus, each pickup head may be moved transversely substantially the width of each tape 10 so that the head may be in playing position on one of the tape's three tracks, or when desired in playing position on two of the three tracks which are next to each other so that the sounds of both of the latter may be reproduced simultaneously. The means for moving the heads transversely to the three track positions is comprised of a knob 59, one of which is provided for each group of tapes, as shown in FIG. 1, and extends outwardly of a front panel 60. The knob has a pointer 61 which may be directed on the panel 60 to circumferentially spaced indicia, such as the letters A, B and C, which indicate the tracks. Positions between two of the letters for positioning the heads to play two tracks on one tape at the same time are similarly indicated. Knob 59 extends outwardly from the device on a rod 64 supported horizontally by a frame member secured to the panel 60 and which has at its inner end a downwardly directed key-forming wire 65, fitted into a vertical open-ended slot 66 in the top of vertical rod 67 secured to slidable support 55. Thus, when knob 59 is rotated to rotate rod 64 and key 66, its rotational movement causes rod 67 and support 55 to move linearly in a horizontal direction to displace the heads to a position under the desired track on each tape in each group.

In FIG. 6, a typical sound reproducing system is shown on which a pickup head 25 is in recording contact with a tape 10, to produce a sound signal which is amplified in the amplifier and reproduced in the speaker 68. To achieve a stereophonic effect a separate sound reproducing system is used for each group of tapes; that is, recordings on the rhythm tapes, the harmony tapes and the melody tapes are each reproduced on a separate speaker or a separate group of speakers.

Referring now to FIGS. 7 and 8, there is illustrated a tape transport system, generally designated as 70, and its electrical circuit. There are two such systems, one for the rhythm and harmony groups of tapes and the other for the melody group. That is, it is desirable to move the rhythm and harmony tapes together because the same sections in both are conveniently, and in most cases, necessarily arranged to have recordings in the same tempo and the same key. To emphasize again, the rhythm tapes have repeated chords recorded thereon to determine the tempo. In contrast to this, the solo or melody producing tapes have individual notes recorded thereon and a melody is created by playing the various solo keys so as to match the tempo of the other two groups of recordings. On each of the two sets of drums 12 and 13 are sprockets 71 and 72 by which the drums are simultaneously rotated in the same direction by means of a chain 73, driven in turn by a sprocket on motor 76. Idler 77 is provided to properly position the chain on the sprocket 72.

The control tape shown in FIG. 7, designated as 78, is of the same material as tape 10 and follows its same path, as may be seen by comparing FIG. 7 with FIG. 2, but has no recording on it. However, it is slotted, as at 82 and 83 in FIG. 8, to break the searching circuit so as to stop the tapes at the desired position so that the one selected section of the six on each tape 10 is in the reservoir 18 in position for playing.

Now referring to FIGS. 1 and 8, the selector knobs 79 are adapted to actuate the appropriate tape transporting circuit when it is desired to transport one of the six sections of the tapes 10 into a playable position in the reservoir 18, and, of course, to remove the tape section presently in the reservoir 18. This is accomplished by the transporting and searching circuit shown in FIG. 8. The two selector knobs 79 shown on the panel 60,

6

have six numbered positions, each of which when the knob is moved to the desired new section number, causes a transport motor 76 to be energized and to drive one set of drums so as to move the tapes either forwardly or rearwardly to one or the other of the drums. The properly located slots, for example, 82 and 83, into which the downwardly biased switches, generally designated as 80, move from a restrained position on the tape 78 serve the purpose to break the transporting circuit and stop the control tape 78 at the proper location.

In FIG. 8, the knob 79 is shown to be in position to have section 1 be in the reservoir 18 and two of the switches 80 have been spring biased into the slots 82 and 83 to break the circuit at C and D. If section 2 of the tapes 10 is to be positioned in the reservoir 18 for playing, springs 80 will move into slots positioned to break the circuit at B and D, similarly, for moving the tape into positions 3, 4, 5 and 6, the slots are positioned so that the circuit is broken at A and D, B and C, C and A, and B and A, respectively.

Thus, for example, if section 3 of the tape 10 is in the reservoir, the switches 80 are open at A and D, that is, spring biased into slots positioned to receive them in tape 78. To transport the tapes 10 so that section 1 will be in the reservoir, the knob 79 is rotated so that its indicator is moved from 3 to 1 on the panel, and this connects the selector switch in contact with the leads C and D. This movement of the selector switch 79 also moves the spring biased manual directional starting switch 84 to the right to make a temporary contact to energize the right rotational relays 85. When the knob 79 is released by the operator, the switch 84 moves back to its normal position where it is held by the force of the springs, the friction on switch 84 supplied by the movement of the selector 79 having been released. By energizing the right rotational relays or flip flops 85, the motor is started and operates to move the tapes so that the switches 80 will move out of the slots and make contact at A and D to close the circuit. The tape 78 is then moved until the switches 80 drop into slots positioned at 82 and 83, and break the circuit at D and C, as shown. When the latter occurs, these contacts being in parallel, the motor will momentarily be de-energized but will instantly energize the left rotational relays generally designated as 88 by means of an automatic friction reverse switch 89 which is mounted on the transport motor shaft. This reversal is required because the momentum of the transport system carries the switches 80 into the slots and past them. However, the reversal means of the switch 89 and the left rotational relays cause the motor to reverse its direction and the switches 80 are again moved into the slots to break the circuit at C and D. The tape 78 will then again have a tendency to move past the slots and if it does, the switch 89 will energize the right rotational relays to move the tape in the reverse direction. This searching operation continues until the switches 80 drop into the slots 82 and 83 and remain there so that the circuit remains broken at C and D. To indicate when the switches 80 are set in the slots 82 and 83 and that the proper sections of tape 10, such as the sections 1, are in the reservoir ready for playing, a safety relay 90 causes an indicator light 91 to be energized. The instrument is then ready for playing with the new recordings on the sections 1.

While the tapes 10 are being transported they should not be depressed by the roller 40 to be placed in contact with the drive roller 28 in that this may cause the tapes to become tangled. To prevent this, a safety switch 94 is provided. Switch 94 when closed makes contact with a spring held wire 95 in the motor circuit which is indicated in the lower left-hand corner of FIG. 8 and in FIG. 1, schematically. Thus, when one of the keys 11 is depressed the transport motor circuit is broken so as to immediately stop the transportation of the tapes and to prevent both a playing and transport movement of the

tapes at the same time to thereby prevent entanglement of the tapes.

As indicated in the operation of control tape 78 whenever the circuit is broken such as by a movement of the switches 80, away from the contacts and then made again by the continual movement of the tape, the circuit is reversed. As is seen in FIG. 7, the control tapes 78 move into the reservoir and through the same path and movements during transporting as the tapes 10. This provides a means for having all the tapes stay in proper alignment for proper timing. In other words, if the control tape 78 is set to move properly with the tapes 10 in the transporting operation, then when it is moved to a proper newly selected location so that the switches 80 break the circuit when entering the slots, all the tapes will have been moved the same amount. Thus, if the control tapes have been moved properly the playing tapes 10 will likewise have been moved the same distance.

However, at the ends of the runs, that is, while moving in the tapes so that section 1 is in playing position or so that section 6 is in playing position in the reservoir, if the control tape (as well as the others) should move too far off the drum as a result of failing to stop in the proper place or fails to shut off the control tape's movement upwardly in the reservoir causes the transport circuit to break by temporarily opening switch 96, shown in FIGS. 3, 7 and 8. The switch 96 is normally held closed by spring contact 97 against a plate 98 in the transport circuit. Thus, if the pulleys 19 and 23 carrying the tape 78 are moved upwardly too far against the force of the spring 30, a switch opening rod 100 is moved upwardly to force the spring 97 off the plate 98 so as to break the transport circuit and, as stated above, to reverse it. After reversal, it will continue to search so that the switches 80 will properly come to rest in the desired slots in the tape 78. Rod 100 is also held downwardly by a spring and when it is permitted to move downwardly after having moved upwardly to open the switch 96 temporarily it is then permitted to move downwardly externally over the end of the spring 97 and to return to its normal position without breaking the circuit, as best seen in FIG. 3, in the U formed in the spring 97.

The recordings on the individual tapes 10 were originally made from the various instruments, as described above, on a magnetic tape traveling at 15 inches per second. These recordings were then reproduced with one recorder and recorded on a second recorder so as to be in proper positions on individual three-track tapes for use in the musical instrument according to the present invention. It is, of course, of utmost importance that the tracks A, B, C on each tape and the tapes 10 be in the proper transverse alignment in their various corresponding sections in the rhythm, harmony and melody groups so that when one or more keys are played in each group concurrently with one or more keys in other groups, the proper timing is achieved in the reproduction of the musical composition. Thus, in making the tapes 10 from the original recordings, the original recording was inserted into one recorder in which the tape traveled at 15 inches per second and the tape on which the copy was to be made was inserted into a second recorder in which the tape moved at $7\frac{1}{2}$ inches per second. The first tape was marked at a starting point and was set in the first recorder to start at said point, and similarly, the second tape was marked and set for starting at the proper point on the tape.

A problem in recording the tapes so that they will be in proper alignment and timing is in bringing the two recorders up to their running speed simultaneously. The problem was solved by securing sprockets for rotation on the drive shafts of the individual recorders, the sprockets having diameters in inverse ratio to the speed of the respective recorders. That is, for example, on the 15 inches per second recorder, the sprocket had 16 teeth and on the $7\frac{1}{2}$ inch per second recorder the sprocket had 32

teeth of the same size so that the diameter of the latter was twice that of the former. Then, an endless chain was placed around the sprocket and the recorders were started simultaneously and about half a second after starting, when the recorders were up to speed, the chain was pulled off the sprocket so that the recorders then ran independently, the one reproducing the sound and the other recording it. The six individual sections recorded on one track of each tape 10 in the second recorder were put on in 8 second time intervals with the proper spacing therebetween. Thus, after the six individual sections were made in one track, the three track tape was rewound and started over in the same manner on the recorder with the magnetic head on the second recorder on the second track.

To better understand the operation of the invention, examples or recordings in the same section and on the same track on each tape in the rhythm, harmony and melody groups which may be played concurrently to produce a musical composition are indicated. For example, in the rhythm group all tapes of the A tracks in the first section have eight second recordings of chords in a standard $\frac{3}{4}$ time waltz, tempo 84, in the key of C. The tempo is determined by the repetitive rate of the recorded chords. Since there are seventeen tapes in the rhythm group, there are seventeen first sections having seventeen A tracks. Thus, when section 1 of the rhythm and harmony section are in the reservoir 18, by playing the first key of the rhythm group, a C chord in $\frac{3}{4}$ waltz time, tempo 84, would be reproduced, the recording having been made by the rhythm type instruments described above. By playing the other sixteen keys in order, the corresponding chords in the key of C, standard waltz time, are reproduced.

In other words, each of the keys 11 in the rhythm group plays one of the aforesaid chords for a period of 8 seconds, if desired, and when appropriate, and it is obvious that there are more than an adequate number of chords in the key of C to play a standard waltz rhythm.

As previously stated, the sections in the rhythm and harmony groups are in fixed alignment and are transported simultaneously. Thus, the sections in the harmony groups have accompaniment chords thereon corresponding to those in the rhythm group, that is, in section 1, track A of the harmony group the recording has been made of a celeste at a standard waltz tempo. The first key in the harmony group is to be played with the first key in the rhythm group, for example, or the same number of keys played in the rhythm group may be correspondingly played in the harmony group. In the aforesaid harmony first section, Track A, each of the seventeen keys, when played causes the reproduction of a complete ten-finger chord in the standard waltz rhythm. Generally, the chords reproduced by the harmony group are traveling chords or licks.

The sections in the melody group are transported separately and any selected instrument recorded thereon, such as violins, may be played along with the waltz rhythm determined by the harmony and rhythm keys. However, in the melody group each key plays one note, the note reproducing keys and tapes being chromatically arranged G through F, and the player must play the keys to create a matching rhythm with that already recorded on the rhythm and harmony groups as he is desirous of doing to obtain the feeling of creative accomplishment.

In the B track of section 1 of the rhythm and harmony groups are recorded the same chords in the key of C as in the track A, but in a Viennese waltz flavor having the tempo of 168 and in the C track of the first section of the same groups are a fox trot tempo of 168 in the key of C in the same 17 chords. By way of further example, the harmony group in section 1 of the B track, to correspond with Viennese waltz flavor,

when played reproduces a ten-man violin pizzicato arpeggio. In other words, in the three respective tracks of the first section in the rhythm and harmony groups, there are a standard waltz, tempo 84, a Viennese waltz, tempo 168, and a fox trot, tempo 168, all in the same key and having the same chords on the corresponding tapes.

To partially show the variations available for reproduction by the present invention in the second, third, fourth, fifth, and sixth sections of the A tracks in the rhythm and harmony groups, there are respectively the C chord of a march in the key of C, 126 beats 2-4 time; the A flat chord of a fox trot, tempo 152; the F chord of a fox trot, tempo 116; the E flat chord of a fox trot, tempo 108; and the B flat chord of a fox trot, tempo 132. The corresponding chords in the same tracks in the same sections as listed above in the A tracks of the first section, follow in the various corresponding tapes in the same sections and A tracks so that a complete musical composition may be reproduced. For example, in the third section, track A of the harmony group, first tape has recorded thereon a key A flat chord for fox trot, tempo 152. This recording was made of a trombone, saxophone and clarinet, as were the other sixteen A tracks in the third section but in different chords, each of which corresponds to the same chord in the rhythm section. Stated differently, in each section in the same tracks, the chords are in the same key and the same chords are in the corresponding tapes in the corresponding tempo. Similarly, the corresponding chords are played by the same musicians and the same combination of instruments. As shown, each group has the same number of keys to provide the same range but a lesser range is adequate and the same range is not required in each group as between rhythm and harmony.

Again, for example, in the third section, track A has recorded thereon a fox trot rhythm, 152 tempo, and the successive tapes in the third section on tracks A have the following 8-second chords: A flat, F minor, B flat₇, B diminished, E flat₇, B flat minor, C sharp, C sharp minor, A diminished, C, F₇, C₇, G₇, E₇, A flat₇, E flat minor, and A flat minor.

In playing, the novice can follow an instruction book having the key numbers thereon in the various groups, and without being able to read any music, can easily learn to play an unlimited number of complete musical compositions with the sound effect of a ten or more piece band.

It is clear that the various recordings and their relationships with each other may be arranged in musical instruments of other forms without departing from the inventive principles disclosed herein whereby the arrangement of reproducible chords and notes will permit any novice to play a complete musical composition.

I claim:

1. In an instrument for playing musical compositions,
 - (a) a rhythm part having
 - (b) a plurality of magnetic recordings, each being capable of reproducing repetitively at least one chord in a predetermined different musical key and predetermined different tempo;
 - (c) a manually operable keyboard, a key of which, when depressed, selects one of said rhythm recordings; and
 - (d) means to reproduce and repeat the selected chord at a selected tempo and for a predetermined time and until said selected key is released.
2. In an instrument for playing musical compositions,
 - (a) a rhythm part having
 - (b) a plurality of magnetic tape recordings, each being capable of reproducing repetitively at least one chord in a predetermined different musical key and predetermined different tempo;
 - (c) a manually operable keyboard, a key of which,

when depressed, selects one of said rhythm recordings; and

- (d) means to reproduce and repeat the selected chord at a selected tempo and for a predetermined time until said selected key is released;
 - (e) a harmony part having
 - (f) a plurality of magnetic tape recordings, each being capable of reproducing a chord in a preselected different musical key and preselected different tempo; and
 - (g) means to select one of said harmony recordings having a musical key to match that of said selected rhythm recording; and
 - (h) means to reproduce the selected harmony chord.
3. In an instrument for playing musical compositions, comprising:
 - (a) a rhythm part having
 - (b) a plurality of magnetic recordings, each being capable of reproducing repetitively at least one chord in a predetermined different key and predetermined different tempo;
 - (c) a manually operable keyboard, a key of which, when depressed, selects one of said rhythm recordings;
 - (d) means to reproduce and repeat the selected chord at a selected tempo and for a predetermined time and until said selected key is released;
 - (e) a harmony part having
 - (f) a plurality of magnetic recordings, each being capable of reproducing a chord in a predetermined different musical key and preselected different tempo; and
 - (g) means to select one of said harmony recordings having a musical key to match that of said selected rhythm recording and to reproduce the selected harmony chord.
 4. An instrument for playing musical compositions, comprising:
 - (a) a rhythm part having
 - (b) a plurality of recordings, each being capable of reproducing repetitively at least one chord in a predetermined different musical key and predetermined different tempo;
 - (c) a plurality of manually operable keys, one of which, when depressed, selects one of said rhythm recordings;
 - (d) means to reproduce and repeat the selected chord for a predetermined time and until said operable key is released;
 - (e) a harmony part having
 - (f) a plurality of recordings, each being capable of reproducing a chord in a predetermined different musical key and predetermined different tempo;
 - (g) means to select one of said harmony recordings having a musical key to match that of said selected rhythm recording and to reproduce the selected harmony chord;
 - (h) a melody part having
 - (i) a plurality of recordings, each being capable of reproducing a different note so that when a plurality of said notes are played a melody may be produced; and
 - (j) means to select one or more of said melody recordings and to reproduce them to produce a melody to match the musical key and tempo of said selected rhythm recording.
 5. An instrument for playing musical compositions, comprising:
 - (a) a rhythm part having
 - (b) a plurality of magnetic recordings, each being capable of reproducing repetitively at least one chord in a predetermined different musical key and predetermined different tempo;
 - (c) a first keyboard including a plurality of manually operable keys, one of which, when depressed, selects one of said rhythm recordings;

11

- (d) means to reproduce and repeat the selected chord for a predetermined time and until said operable key is released;
- (e) a harmony part having
- (f) a plurality of magnetic recordings, each being capable of reproducing a chord in a preselected different musical key and predetermined different tempo; 5
- (g) a second keyboard to select one of said harmony recordings having a musical key to match that of said selected rhythm recording; 10
- (h) means to reproduce the selected harmony chord;
- (i) a melody part having
- (j) a plurality of magnetic recordings, each being capable of reproducing a different note so that when a plurality of said notes are played a melody may be produced; 15
- (k) a third keyboard to select one or more of said melody recordings; and
- (l) means to reproduce them to produce a melody to match the musical key and tempo of said selected rhythm recording. 20
6. An instrument for playing musical compositions comprising:
- (a) a rhythm part having
- (b) a plurality of recordings, each being capable of reproducing repetitively at least one chord in a predetermined different musical key and predetermined different tempo; 25
- (c) a plurality of manually operable keys, one of which, when depressed, selects one of said rhythm recordings; 30
- (d) means to reproduce and repeat the selected chord for a predetermined time and until said operable key is released;
- (e) a harmony part having

12

- (f) a plurality of recordings, each being capable of reproducing a chord in a predetermined different musical key and predetermined different tempo;
- (g) means to select one of said harmony recordings having a musical key to match that of said selected rhythm recordings and to reproduce the selected harmony chord;
- (h) a melody part having
- (i) a plurality of recordings, each being capable of reproducing a different note so that when a plurality of said notes are played a melody may be produced;
- (j) means to select one or more of said melody recordings and to reproduce them to produce a melody to match the musical key and tempo of said selected rhythm recording; and
- (k) means to rapidly select in unison a different set of recordings in said rhythm and in said harmony part having matching musical keys and tempos.

References Cited by the Examiner

UNITED STATES PATENTS

| | | | |
|-----------|---------|------------------|----------|
| 2,471,534 | 5/1949 | Muth et al. | 84—1.28 |
| 2,533,461 | 12/1950 | Illsley | 84—1.28 |
| 2,607,256 | 8/1952 | Pattyn | 84—1.28 |
| 2,645,968 | 7/1953 | Hanert | 84—1.22 |
| 2,645,969 | 7/1953 | Daniel | 84—1.28 |
| 2,784,632 | 3/1957 | Christ | 84—1.28 |
| 2,910,298 | 10/1959 | Chamberlin | 274—4 |
| 2,940,351 | 6/1960 | Chamberlin | 84—1.28 |
| 3,007,703 | 11/1961 | Davies | 242—57 X |
| 3,166,328 | 1/1965 | Roberts | 274—4 |

ARTHUR GAUSS, *Primary Examiner.*

35 I. C. EDELL, *Assistant Examiner.*